

039202500H

# PDE Electric cooling pump



Discover the new BOSCH PDE coolant pump, crafted for a wide array of applications. With its optimized performance for rapid charging and simultaneous cooling of two electric axles, it offers an effective solution for all-wheel drive electric vehicles.

The pump is distinguished by its low noise emissions and robust construction, ensuring a lifespan of up to 41,000 hours.

- **Degree of protection:** IP6KX, IPX7, IPX9K
- **Operating mode:** S1
- **Nominal Voltage:** 12 V



[Contact us!](#)

## Product Specification

### Technical data and performance curve

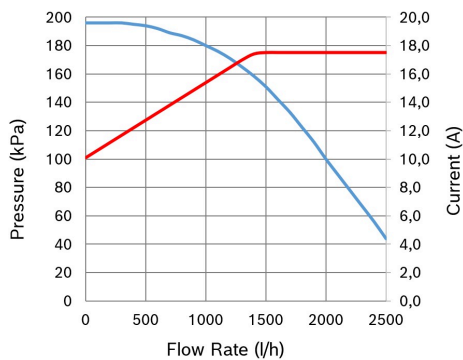

**Flow rate (l/h):** 1200

**Nominal pressure (bar):** 1.7

**Nominal Voltage (V):** 12

**Weight (kg):** 0.7

**Control:** PWM

**Medium:** Water/Glycol (50/50)

Product images and pictures are for demonstration purposes only, the actual product may differ from the picture shown. The quotation drawing is binding.

Robert Bosch GmbH, Auf der Breit 4, 76227 Karlsruhe, Germany [www.bosch-ibusiness.com](http://www.bosch-ibusiness.com)



## Dimensions

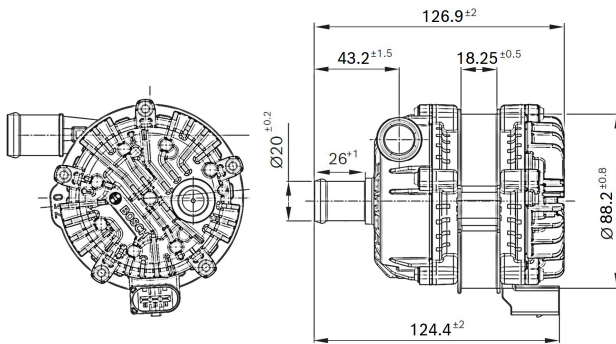

Please contact us if you need a 3d model

[Contact](#)

## Connector

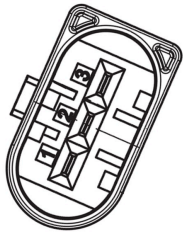

+ Pin 3  
S Pin 2  
– Pin 1

### Housing:

- Hirschmann 3-way, coding A [805-199-521]

### Terminal:

- Kostal SLK 2.8 [22124492075]

### Seal:

- Kostal [10800444523]

## Downloads

You may also be interested in:

To Product family: [Catalogue](#)

