

0390249101

WDD2 Direct wiper drive



An adaptable wiper motor for a wide variety of systems on the market!

Smart technology for an excellent view: with up to eight wiper motors running synchronously per cabin and a maximum wiping angle of 345°, Bosch wiper motors offer an outstanding level of clarity at all times both on and off the road. Bosch WDD2 wiper motor is the ideal solution for applications that demand maximum wiping effectiveness.

- **Degree of protection:** IP 6K7
- **Wiping angle:** Up to 350°
- **LIN/CAN (2.0) / analog communication**
- **Nominal voltage:** Compatible for 12V
- **Adjustable speed, angle and torque**

[Contact us!](#)

Product Specification

Technical data and performance curve

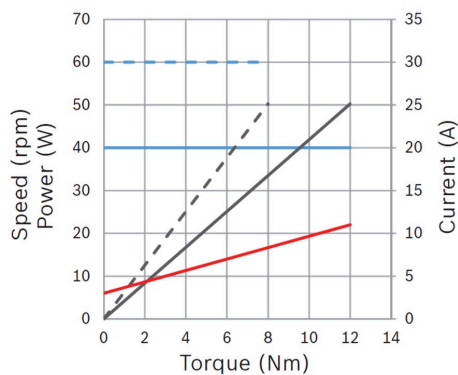

Nominal power (W): 50

Nominal current (A): 8,3

Nominal speed (rpm): 60 / 40

Nominal torque (Nm): 8 / 12

Stall torque (Nm): 34

Transmission ratio: 76:1

Signal-LIN: LIN

Product images and pictures are for demonstration purposes only, the actual product may differ from the picture shown. The quotation drawing is binding.

Robert Bosch GmbH, Auf der Breit 4, 76227 Karlsruhe, Germany www.bosch-ibusiness.com



Dimensions

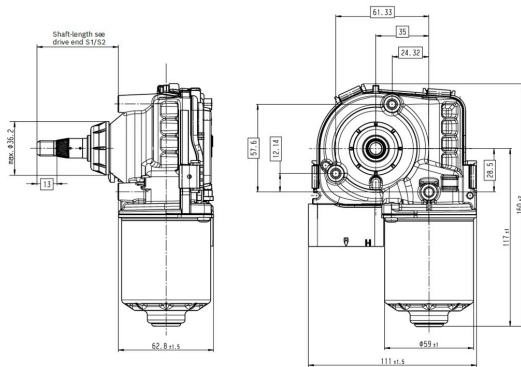

Please contact us if you need a 3d model

[Contact](#)

Circuit diagram

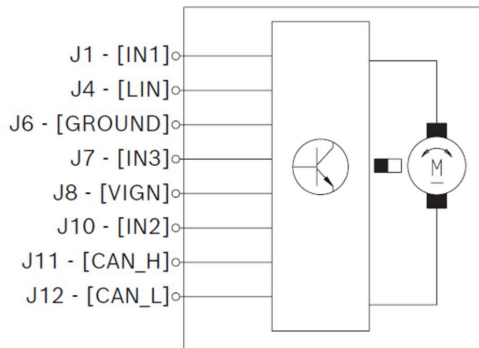

Connector

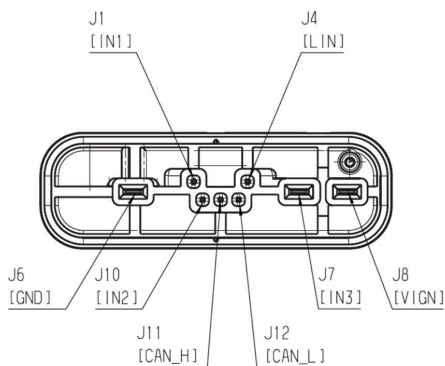

Housing:

MOLEX

variant 31034-5016

Locker:

-

PIN:

1393367-1,

1326032-6,



Drive interface

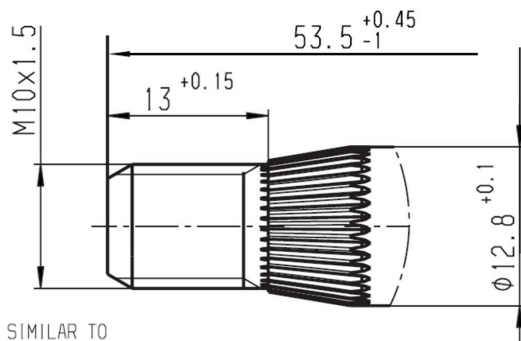

SHAFT END SIMILAR TO
DIN 72783-A2

Features and benefits

- Models with integrated electronics: Suitable for a wide range of applications and depending on model equipped with bus communication digital/LIN/CAN as well as teach-in functions
- Rotation in both directions: For using the motor as a drive or as an actuator
- Production in line with the original automotive quality guidelines: For proven quality, high reliability and a long service life
- Operating mode S1: Suitable for continuous operation

Downloads

You may also be interested in:

To Product family: [Catalogue](#)

